

Utilizing the latest Field Stop and Trench Gate technologies, these IGBT's have ultra low  $V_{CE(ON)}$  and are ideal for low frequency applications that require absolute minimum conduction loss. Easy paralleling is a result of very tight parameter distribution and a slightly positive  $V_{CE(ON)}$  temperature coefficient. A built-in gate resistor ensures extremely reliable operation, even in the event of a short circuit fault. Low gate charge simplifies gate drive design and minimizes losses.

- **1200V Field Stop**
- **Trench Gate: Low  $V_{CE(on)}$**
- **Easy Paralleling**
- **Intergrated Gate Resistor: Low EMI, High Reliability**

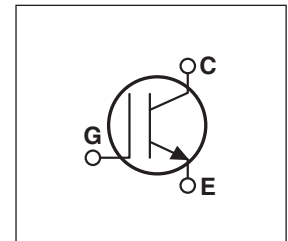
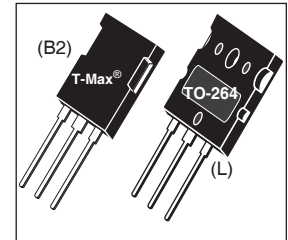

**Applications: Welding, Inductive Heating, Solar Inverters, SMPS, Motor drives, UPS**

### MAXIMUM RATINGS

All Ratings:  $T_C = 25^\circ\text{C}$  unless otherwise specified.

| Symbol         | Parameter  | APT75GN120B2_L(G) | UNIT             |
|----------------|--|-------------------|------------------|
| $V_{CES}$      | Collector-Emitter Voltage  | 1200              | Volts            |
| $V_{GE}$       | Gate-Emitter Voltage   | $\pm 30$          |                  |
| $I_{C1}$       | Continuous Collector Current <sup>③</sup> @ $T_C = 25^\circ\text{C}$ | 200               | Amps             |
| $I_{C2}$       | Continuous Collector Current @ $T_C = 110^\circ\text{C}$             | 99                |                  |
| $I_{CM}$       | Pulsed Collector Current <sup>①</sup> @ $T_C = 150^\circ\text{C}$    | 225               |                  |
| SSOA           | Switching Safe Operating Area @ $T_J = 150^\circ\text{C}$            | 225A @ 1200V      |                  |
| $P_D$          | Total Power Dissipation  | 833               | Watts            |
| $T_J, T_{STG}$ | Operating and Storage Junction Temperature Range                     | -55 to 150        | $^\circ\text{C}$ |
| $T_L$          | Max. Lead Temp. for Soldering: 0.063" from Case for 10 Sec.          | 300               |                  |

### STATIC ELECTRICAL CHARACTERISTICS

| Symbol        | Characteristic / Test Conditions  | MIN  | TYP | MAX | Units         |
|---------------|---|------|-----|-----|---------------|
| $V_{(BR)CES}$ | Collector-Emitter Breakdown Voltage ( $V_{GE} = 0V, I_C = 3mA$ )                                  | 1200 |     |     | Volts         |
| $V_{GE(TH)}$  | Gate Threshold Voltage ( $V_{CE} = V_{GE}, I_C = 3mA, T_J = 25^\circ\text{C}$ )                   | 5.0  | 5.8 | 6.5 |               |
| $V_{CE(ON)}$  | Collector-Emitter On Voltage ( $V_{GE} = 15V, I_C = 75A, T_J = 25^\circ\text{C}$ )                | 1.4  | 1.7 | 2.1 |               |
|               | Collector-Emitter On Voltage ( $V_{GE} = 15V, I_C = 75A, T_J = 125^\circ\text{C}$ )               |      | 2.0 |     |               |
| $I_{CES}$     | Collector Cut-off Current ( $V_{CE} = 1200V, V_{GE} = 0V, T_J = 25^\circ\text{C}$ ) <sup>②</sup>  |      |     | 100 | $\mu\text{A}$ |
|               | Collector Cut-off Current ( $V_{CE} = 1200V, V_{GE} = 0V, T_J = 125^\circ\text{C}$ ) <sup>②</sup> |      |     | TBD |               |
| $I_{GES}$     | Gate-Emitter Leakage Current ( $V_{GE} = \pm 20V$ )   |      |     | 600 | nA            |
| $R_{G(int)}$  | Intergrated Gate Resistor   |      | 10  |     | $\Omega$      |



**CAUTION:** These Devices are Sensitive to Electrostatic Discharge. Proper Handling Procedures Should Be Followed.

## DYNAMIC CHARACTERISTICS

APT75GN120B2\_L(G)

| Symbol       | Characteristic                                | Test Conditions  | MIN  | TYP  | MAX   | UNIT |    |
|--------------|---|--|--|------|-------|------|----|
| $C_{ies}$    | Input Capacitance                             | <b>Capacitance</b><br>$V_{GE} = 0V, V_{CE} = 25V$<br>$f = 1 \text{ MHz}$   |  | 4800 |       | pF   |    |
| $C_{oes}$    | Output Capacitance                            |  |  | 275  |       |      |    |
| $C_{res}$    | Reverse Transfer Capacitance                  |  |  | 210  |       |      |    |
| $V_{GEP}$    | Gate-to-Emitter Plateau Voltage               | Gate Charge<br>$V_{GE} = 15V$<br>$V_{CE} = 600V$<br>$I_C = 75A$  |  | 9.0  |       | V    |    |
| $Q_g$        | Total Gate Charge <sup>③</sup>                |  |  | 425  |       | nC   |    |
| $Q_{ge}$     | Gate-Emitter Charge                           |  |  | 30   |       |      |    |
| $Q_{gc}$     | Gate-Collector ("Miller") Charge              |  |  | 245  |       |      |    |
| SSOA         | Switching Safe Operating Area                 | $T_J = 150^\circ\text{C}, R_G = 4.3\Omega^{\text{⑦}}, V_{GE} = 15V, L = 100\mu\text{H}, V_{CE} = 1200V$  | 225  |      |       | A    |    |
| $t_{d(on)}$  | Turn-on Delay Time                            | <b>Inductive Switching (25°C)</b><br>$V_{CC} = 800V$<br>$V_{GE} = 15V$<br>$I_C = 75A$<br>$R_G = 1.0\Omega^{\text{⑦}}$<br>$T_J = +25^\circ\text{C}$ |  | 60   |       | ns   |    |
| $t_r$        | Current Rise Time                             |  |  | 41   |       |      |    |
| $t_{d(off)}$ | Turn-off Delay Time                           |  |  | 620  |       |      |    |
| $t_f$        | Current Fall Time                             |  |  | 110  |       |      |    |
| $E_{on1}$    | Turn-on Switching Energy <sup>④</sup>         |  |  |      | 8045  |      | μJ |
| $E_{on2}$    | Turn-on Switching Energy (Diode) <sup>⑤</sup> |  |  |      | 9620  |      |    |
| $E_{off}$    | Turn-off Switching Energy <sup>⑥</sup>        |  |  |      | 7640  |      |    |
| $t_{d(on)}$  | Turn-on Delay Time                            |  | <b>Inductive Switching (125°C)</b><br>$V_{CC} = 800V$<br>$V_{GE} = 15V$<br>$I_C = 75A$<br>$R_G = 1.0\Omega^{\text{⑦}}$<br>$T_J = +125^\circ\text{C}$ |      | 60    |      | ns |
| $t_r$        | Current Rise Time                             |  |  | 41   |       |      |    |
| $t_{d(off)}$ | Turn-off Delay Time                           |  |  | 725  |       |      |    |
| $t_f$        | Current Fall Time                             |  |  | 200  |       |      |    |
| $E_{on1}$    | Turn-on Switching Energy <sup>④</sup>         |  |  |      | 8620  |      | μJ |
| $E_{on2}$    | Turn-on Switching Energy (Diode) <sup>⑤</sup> |  |  |      | 13000 |      |    |
| $E_{off}$    | Turn-off Switching Energy <sup>⑥</sup>        |  |  |      | 11400 |      |    |

## THERMAL AND MECHANICAL CHARACTERISTICS

| Symbol          | Characteristic           | MIN | TYP | MAX | UNIT |
|-----------------|--------------------------|-----|-----|-----|------|
| $R_{\theta JC}$ | Junction to Case (IGBT)  |     |     | .15 | °C/W |
| $R_{\theta JC}$ | Junction to Case (DIODE) |     |     | N/A |      |
| $W_T$           | Package Weight           |     | 5.9 |     | gm   |

- ① Repetitive Rating: Pulse width limited by maximum junction temperature.
- ② For Combi devices,  $I_{ces}$  includes both IGBT and FRED leakages
- ③ See MIL-STD-750 Method 3471.
- ④  $E_{on1}$  is the clamped inductive turn-on energy of the IGBT only, without the effect of a commutating diode reverse recovery current adding to the IGBT turn-on loss. Tested in inductive switching test circuit shown in figure 21, but with a Silicon Carbide diode.
- ⑤  $E_{on2}$  is the clamped inductive turn-on energy that includes a commutating diode reverse recovery current in the IGBT turn-on switching loss. (See Figures 21, 22.)
- ⑥  $E_{off}$  is the clamped inductive turn-off energy measured in accordance with JEDEC standard JESD24-1. (See Figures 21, 23.)
- ⑦  $R_G$  is external gate resistance, not including  $R_{G(int)}$  nor gate driver impedance. (MIC4452)
- ⑧ Current limited by lead temperature.

APT Reserves the right to change, without notice, the specifications and information contained herein.

# TYPICAL PERFORMANCE CURVES

APT75GN120B2\_L(G)

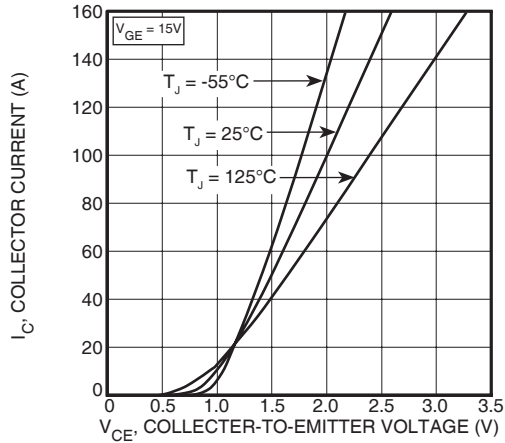

FIGURE 1, Output Characteristics( $T_J = 25^\circ\text{C}$ )

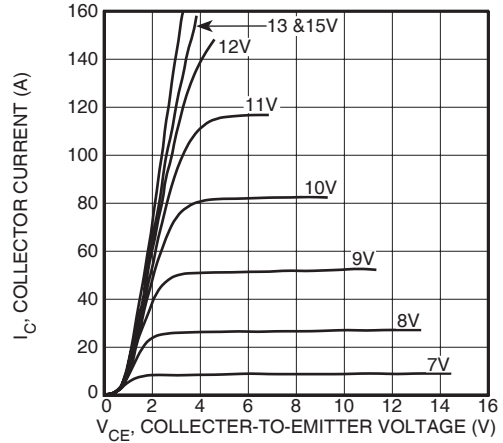

FIGURE 2, Output Characteristics ( $T_J = 125^\circ\text{C}$ )

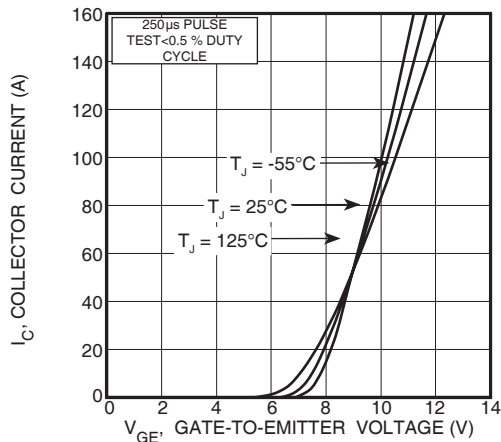

FIGURE 3, Transfer Characteristics

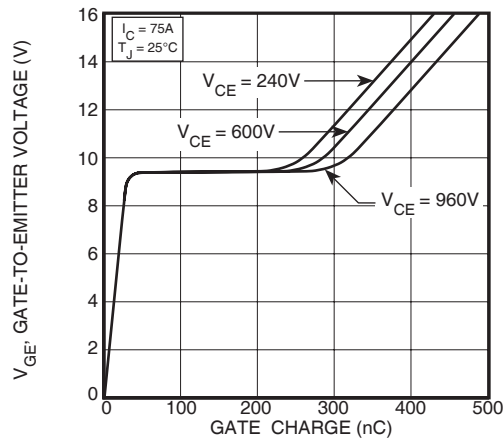

FIGURE 4, Gate Charge

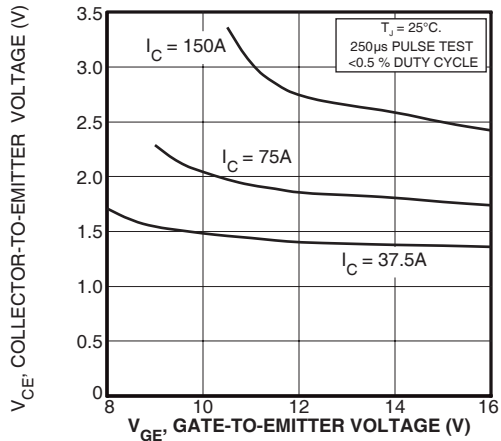

FIGURE 5, On State Voltage vs Gate-to-Emitter Voltage

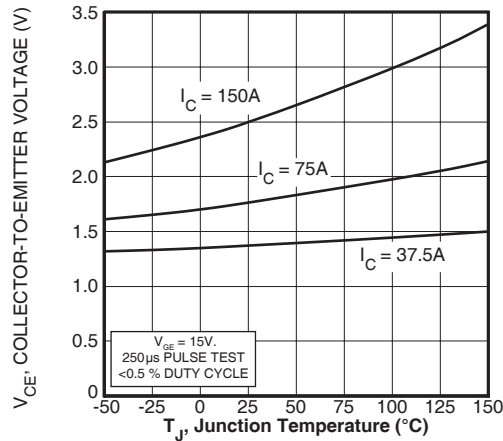

FIGURE 6, On State Voltage vs Junction Temperature

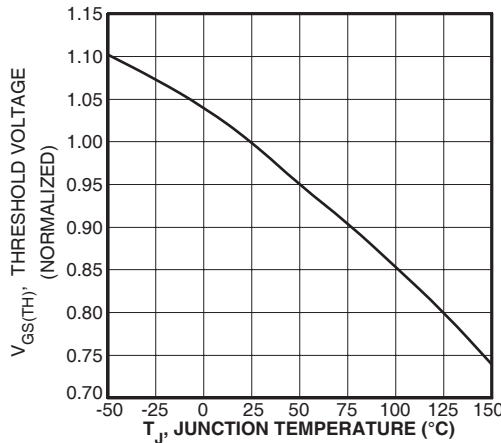

FIGURE 7, Threshold Voltage vs. Junction Temperature

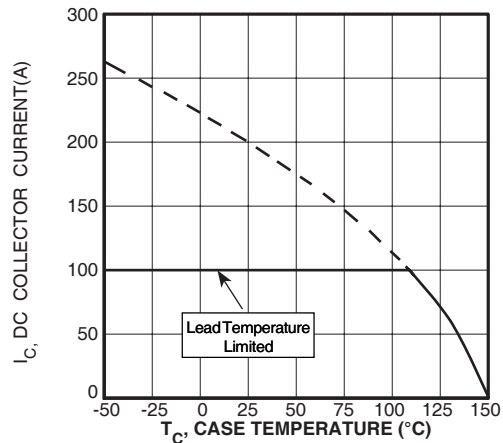

FIGURE 8, DC Collector Current vs Case Temperature



FIGURE 9, Turn-On Delay Time vs Collector Current

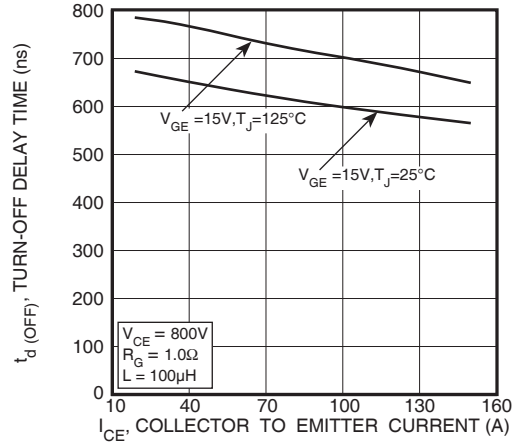

FIGURE 10, Turn-Off Delay Time vs Collector Current

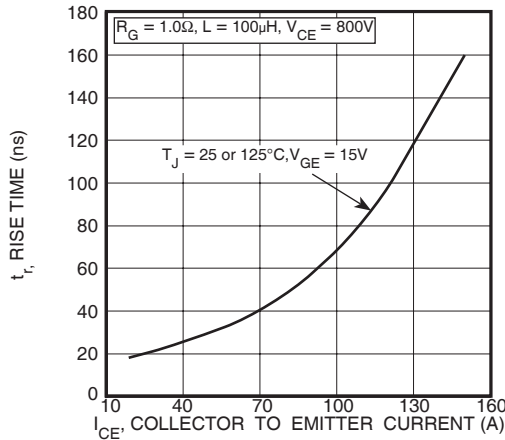

FIGURE 11, Current Rise Time vs Collector Current

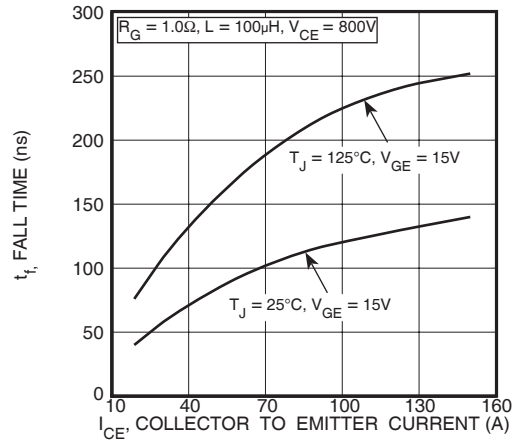

FIGURE 12, Current Fall Time vs Collector Current

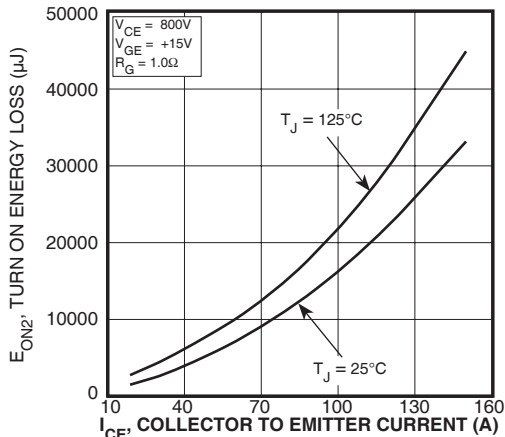

FIGURE 13, Turn-On Energy Loss vs Collector Current

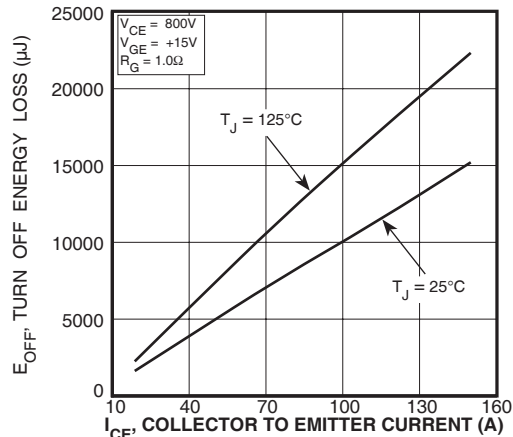

FIGURE 14, Turn Off Energy Loss vs Collector Current

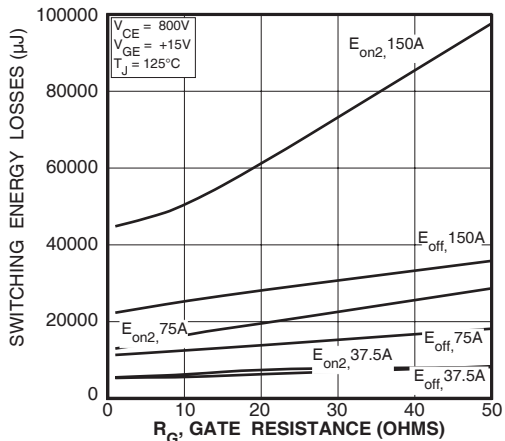

FIGURE 15, Switching Energy Losses vs. Gate Resistance

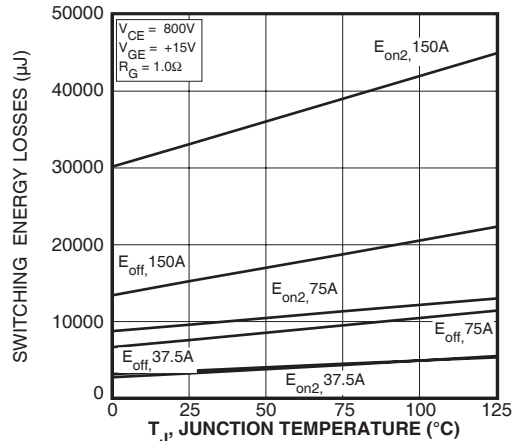

FIGURE 16, Switching Energy Losses vs Junction Temperature

**TYPICAL PERFORMANCE CURVES**

**APT75GN120B2\_L(G)**

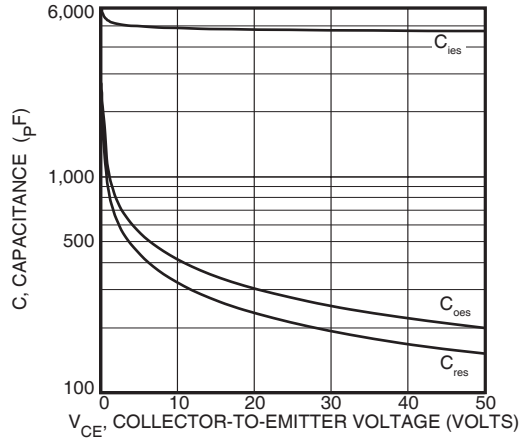

Figure 17, Capacitance vs Collector-To-Emitter Voltage

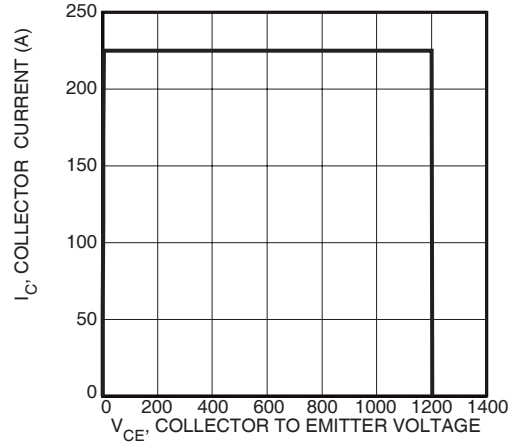

Figure 18, Minimum Switching Safe Operating Area

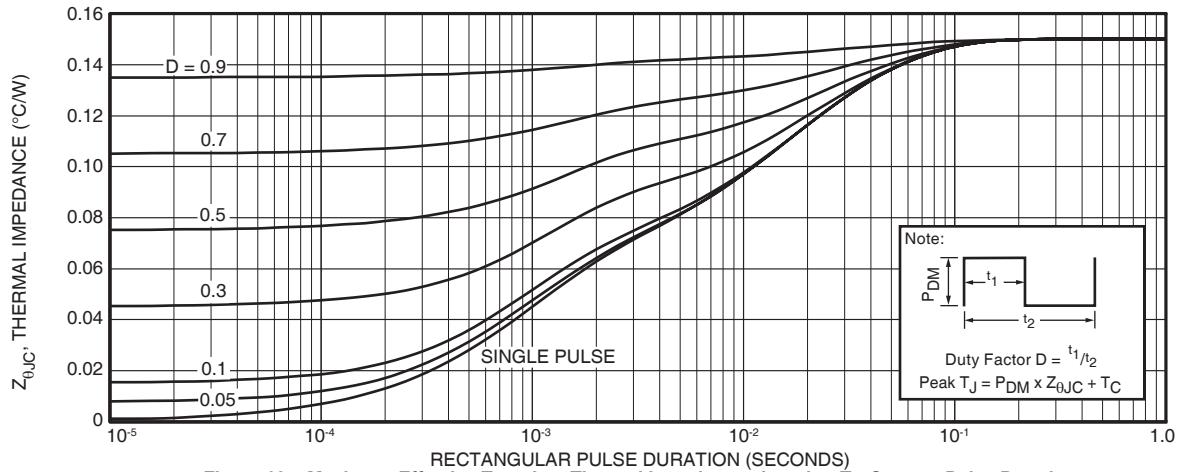

Figure 19a, Maximum Effective Transient Thermal Impedance, Junction-To-Case vs Pulse Duration

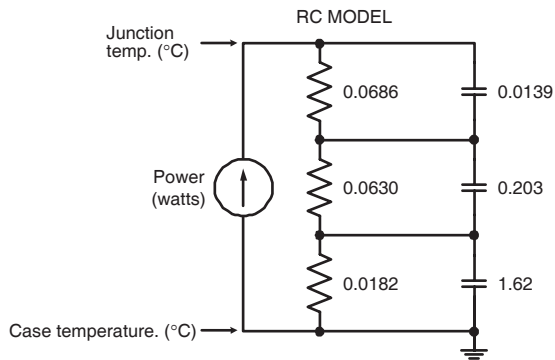

FIGURE 19b, TRANSIENT THERMAL IMPEDANCE MODEL

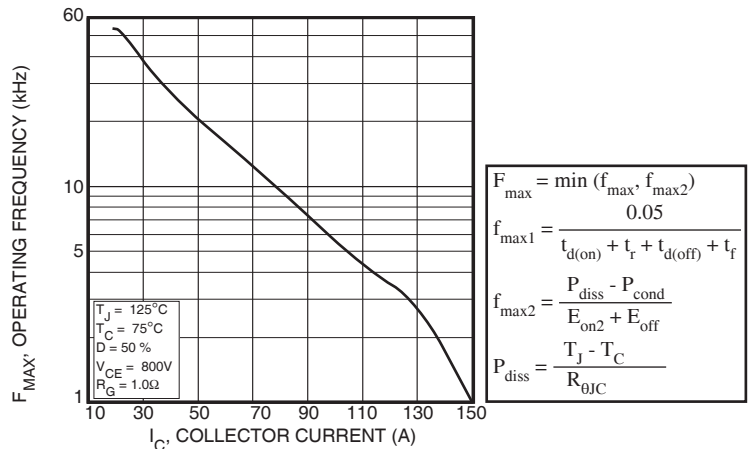

Figure 20, Operating Frequency vs Collector Current

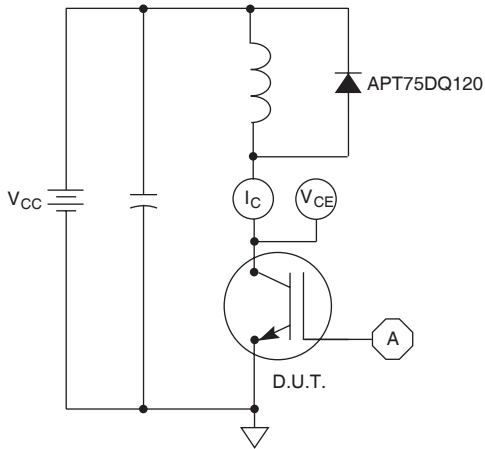

Figure 21, Inductive Switching Test Circuit

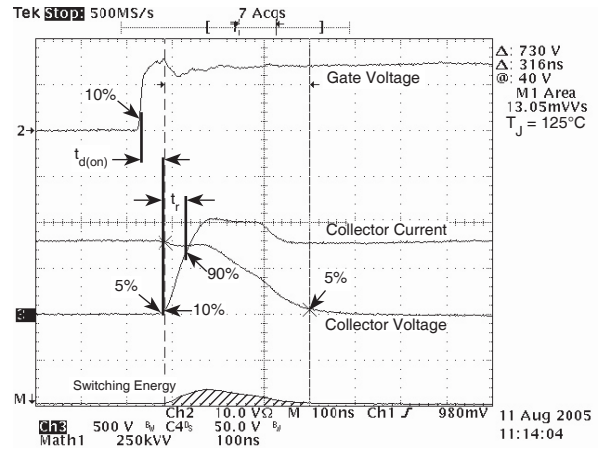

Figure 22, Turn-on Switching Waveforms and Definitions

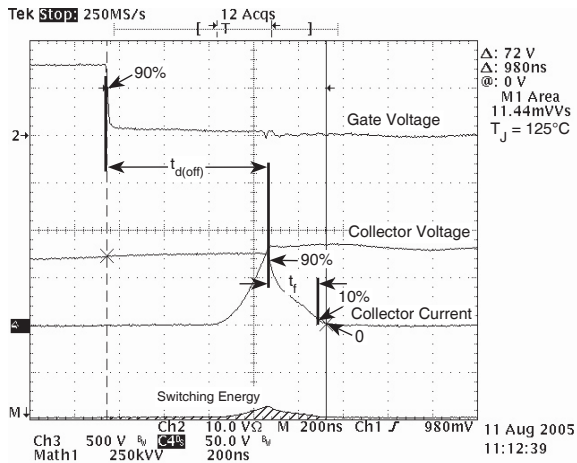
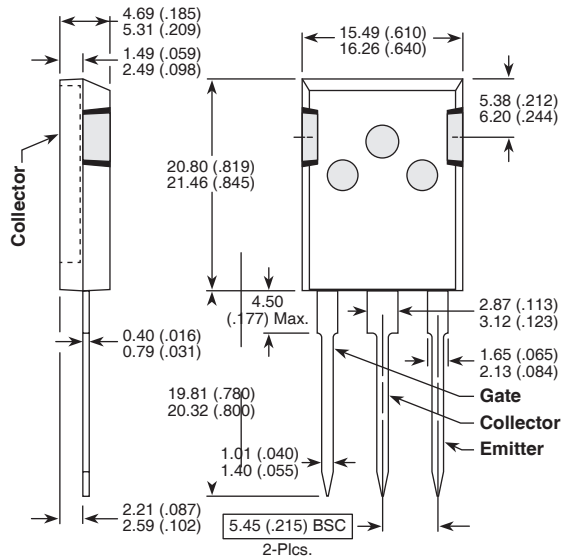

Figure 23, Turn-off Switching Waveforms and Definitions

T-MAX® (B2) Package Outline

① SAC: Tin, Silver, Copper



Dimensions in Millimeters and (Inches)

TO-264(L) Package Outline

① SAC: Tin, Silver, Copper

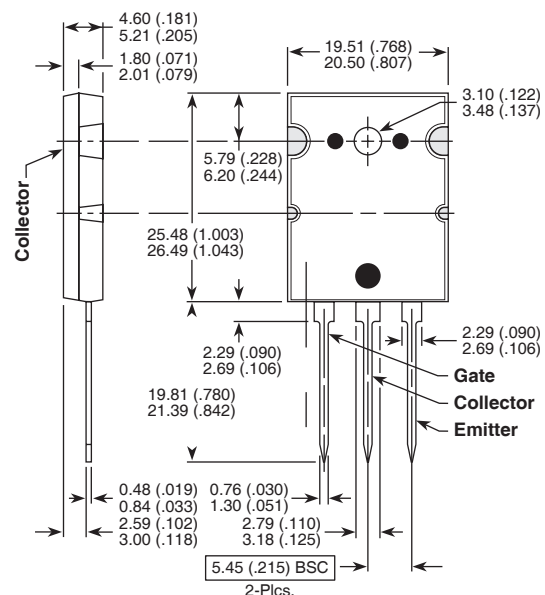

Dimensions in Millimeters and (Inches)